

TRADE OF
Pipefitting

PHASE 2

Module 5

Technical Drawing

UNIT: 3

Drawing Equipment & Practice

Produced by

SOLAS

An tSeirbhís Oideachais Leanúnaigh agus Scileanna
Further Education and Training Authority

In cooperation with subject matter expert:

Finbar Smith

© SOLAS 2014

Table of Contents

Unit Objective	1
Learning Outcome	2
1.0 Drawing Practical	3
1.1 Set of Manual Drawing Equipment	3
1.2 Line Styles and Types	4
2.0 Drawing Practical	6
2.1 Exercise No. 2.5.3a	7
2.2 Exercise No. 2.5.3b	8
2.3 Exercise No. 2.5.3c	9
2.4 Exercise No. 2.5.3d	10
2.5 Exercise No. 2.5.3e	11
Exercises	12
Additional Resources	13

Unit Objective

There are five units in Module 5. Unit 1 focuses on Drawing Methods & Types, Unit 2; Standard Drawing Conventions, Unit 3; Drawing Equipment & Practice, Unit 4; Drawings for Piping Installation, Unit 5; Traceability Record.

In this unit you will be introduced to Drawing Equipment and Practice.

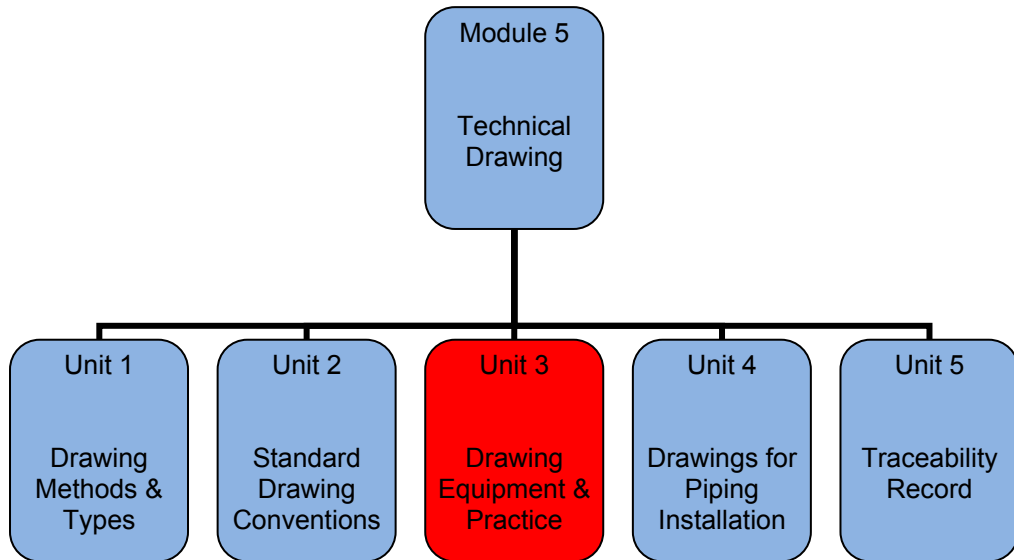

Learning Outcome

By the end of this unit each apprentice will be able to:

- Identify the basic drawing equipment and aids used for technical drawing
- Identify the basic line styles and types used on drawings
- Identify, select and use the necessary drawing instruments to set up and prepare a drawing sheet for a practical drawing exercise
- Produce basic isometric line drawings and first/third angle orthographic projection drawings as per Exercise Nos. 2.5.3a, 2.5.3b, 2.5.3c and 2.5.3d
- Using parallel line development draw the given view of a 90° pipe junction between two pipes of different diameters and develop a full template for the branch pipe, then project a true shape of the hole in the main pipe as per Exercise No. 2.5.3e

1.0 Drawing Practical

Key Learning Points

- Identify equipment needed to complete a paper drawing.
- Identify different types and styles of lines used in drawings

1.1 Set of Manual Drawing Equipment

Admittedly, in the computer era, technical drawing does not play the same role as in the past. However to complete a CAD drawing the user must understand the basics of technical drawing and know how to set out a drawing. The rules for putting technical drawings on paper also apply to setting out a drawing on the computer screen. Figure 1 below illustrates some of the equipment required to create a technical drawing on paper. To create a paper drawing you will need the following basic set of equipment:

- Drawing board, which allows the fixing of paper in such a way that it does not slip.
- T-squares: A2 size, Tape Blade, best quality hardwood, with maple edges to blade and stock; blade screwed and dowelled to stock or equal. The T-square is used to line the sheet up on the board and draw horizontal lines on the drawing.
- The size of the set squares is expressed in cm (mm) as the hypotenuse length for right-angled squares.
- 60°/30° Set Square transparent heavy duty, non-brittle plastic, with beveled edge and open centre. Size: 200 mm, 2 mm thick.
- 45° Set Square transparent heavy duty, non-brittle plastic, with beveled edge and open centre. Size: 200 mm, 2 mm thick.
- Protractor, acrylic to suit graphics/drawing
- Compass set with steel point (100 mm),
- Circle template, acrylic type, c.2 mm to 50 mm diameter circles
- Erasing shield, stainless steel type.



Figure 1 – Technical drawing equipment

1.2 Line Styles and Types

A good drawing depends on the density and uniformity of the lines and lettering being consistent.

Pencil lines should be opaque and of uniform width throughout their length. The line widths which are specified for ink lines do not apply to pencil lines. Cutting and viewing plane lines are the thickest lines on the drawing. However, the thick lines used for outlines and other visible lines shall be sufficiently prominent to immediately differentiate them from lines used for other purposes. Hidden, sectioning, center, phantom, extension, dimension, and leader lines shall be thinner than outlines. A variety of line styles graphically represent physical objects. Different line types are shown in Figure 2 below and include the following:

- *visible* – are continuous lines used to depict edges directly visible from a particular angle.
- *hidden* – are short-dashed lines that may be used to represent edges that are not directly visible.
- *center* – are alternately long- and short-dashed lines that may be used to represent the axes of circular features.
- *cutting plane* – are thin, medium-dashed lines, or thick alternately long- and double short-dashed that may be used to define sections for sectional views.
- *section* – are thin lines in a pattern (pattern determined by the material being "cut" or "sectioned") used to indicate surfaces in section views resulting from "cutting." Section lines are commonly referred to as "cross-hatching."
- *phantom* - (not shown) are alternately long- and double short-dashed thin lines used to represent a feature or component that is not part of the specified part or assembly. E.g. billet ends that may be used for testing, or the machined product that is the focus of a tooling drawing.

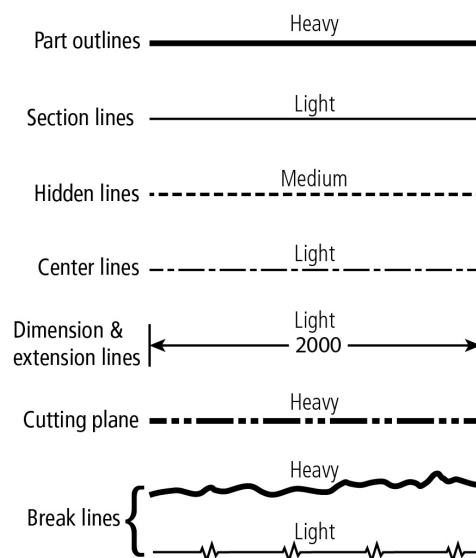



Figure 2 – Styles and line types for different parts of a drawing



Lines, whether hand-drawn or plotted, shall be opaque and of uniform width for each type of line. Two widths of lines, i.e., thin and thick, with their widths in the proportions of 1:2, shall be used. The actual width of each type of line shall be governed by the size and style of the drawing; the relative widths of the lines shall approximate those as shown in Figure 2 above.

2.0 Drawing Practical

Key Learning Points

- Identify the correct method of setting up a sheet for drawing exercises.
- Produce basic isometric line drawings
- Produce basic first/third angle orthographic projection drawings
- Using parallel line development draw the given view of a 90° pipe junction between two pipes of different diameters and develop a full template for the branch pipe, then project a true shape of the hole in the main pipe

Practical Task

This is a practical task. Please refer to relevant sections of the course notes and your instructor for additional information and instruction.

2.1 Exercise No. 2.5.3a

Pipefitting

Code XX

Phase 2

Module 5: Unit 3

Exercise No. 2.5.3a

Instructions

- Draw Exercise 2.5.3a
- Draw basic first and third angle orthographic projection drawing
- Draw basic isometric line drawing

Tools and Materials

- Drawing equipment
- Information sheets
- Reference books
- Notebook

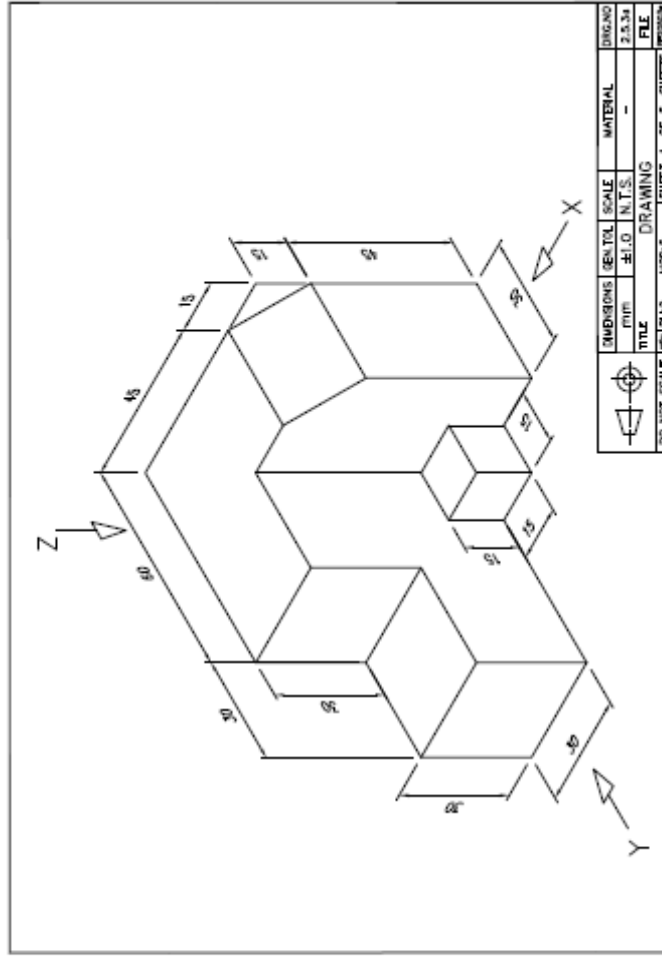

	UNIT	SCALE	MATERIAL
	MM	1:1	---
TITLE		DRAWING	
NO NOT SCALE		MOD:5	SHEET 1 OF 5
PH:3		SHEETS	
DIMENSIONS		DATE	
2.5.3a		FILE	
PROVISION		DATE	

Standards All drawings interpreted and drawing correct. Drawings neat and balanced

2.2 Exercise No. 2.5.3b

Pipefitting

Phase 2

Code XX

Module 5: Unit 3

Exercise No. 2.5.3b

Instructions

- Draw Exercise 2.5.3b
- Draw basic first and third angle orthographic projection drawings
- Produce basic isometric line drawing

Tools and Materials

- Drawing equipment
- Information sheets
- Reference books
- Notebook

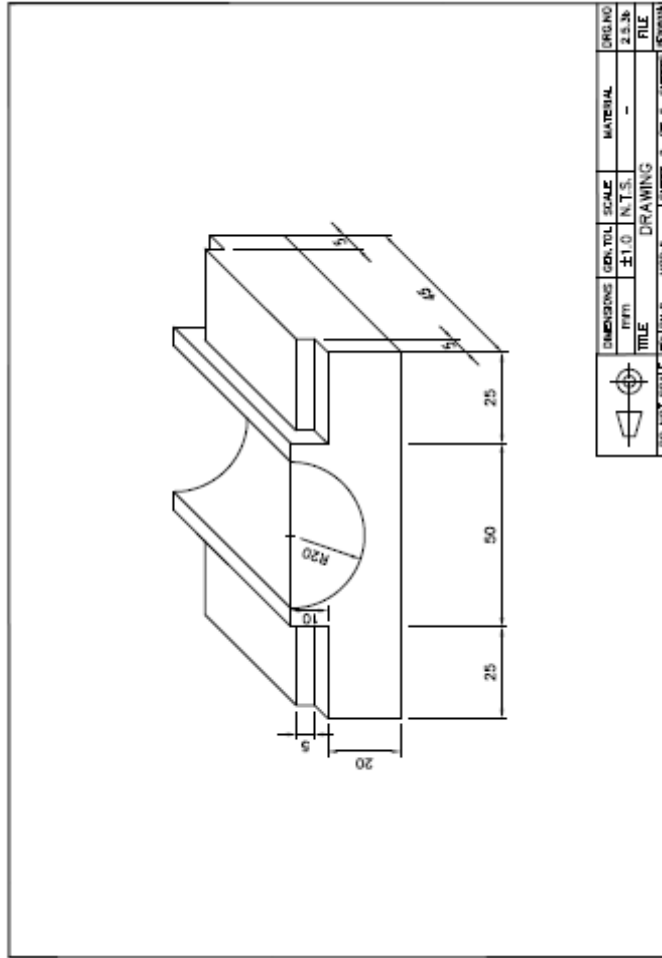

Standards All drawings interpreted and drawing correct. Drawings neat and balanced

2.3 Exercise No. 2.5.3c

Code XX

Phase 2

Module 5: Unit 3

Pipefitting

Exercise No. 2.5.3c

Instructions

- Drawing Exercise 2.5.3c
- Draw first and third angle orthographic projection drawings
- Produce basic isometric line drawing
- Read and interpret working drawing

Tools and Materials

- Drawing equipment
- Information sheets
- Reference books
- Notebook

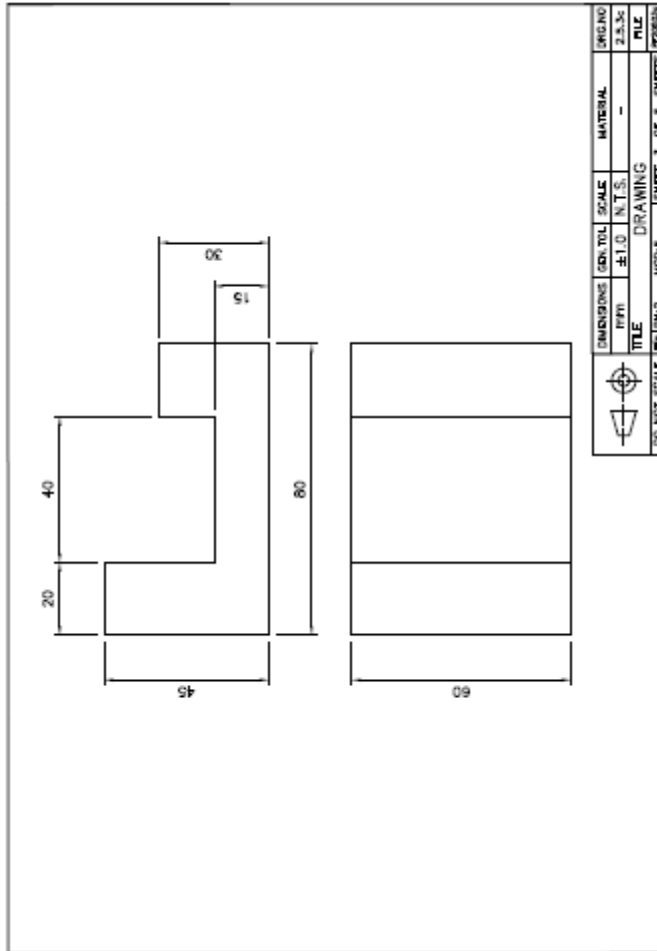

CONTR. NO.	SCALE	MATERIAL	DRAWING
1/1	N.T.S.	-	2.5.3c
TITLE DRAWING			
SHEET 3 OF 3 SHEETS		REVISED	

Standards All drawings interpreted and drawing correct. Drawings neat and balanced

2.4 Exercise No. 2.5.3d

Code XX

Phase 2

Module 5: Unit 3

Pipefitting

Exercise No. 2.5.3d

Instructions

- Drawing Exercise 2.5.3d
- Draw basic first and third angle orthographic projection drawings
- Produce basic isometric line drawing
- Read and interpret working drawing

Tools and Materials

- Drawing equipment
- Information sheets
- Reference books
- Notebook

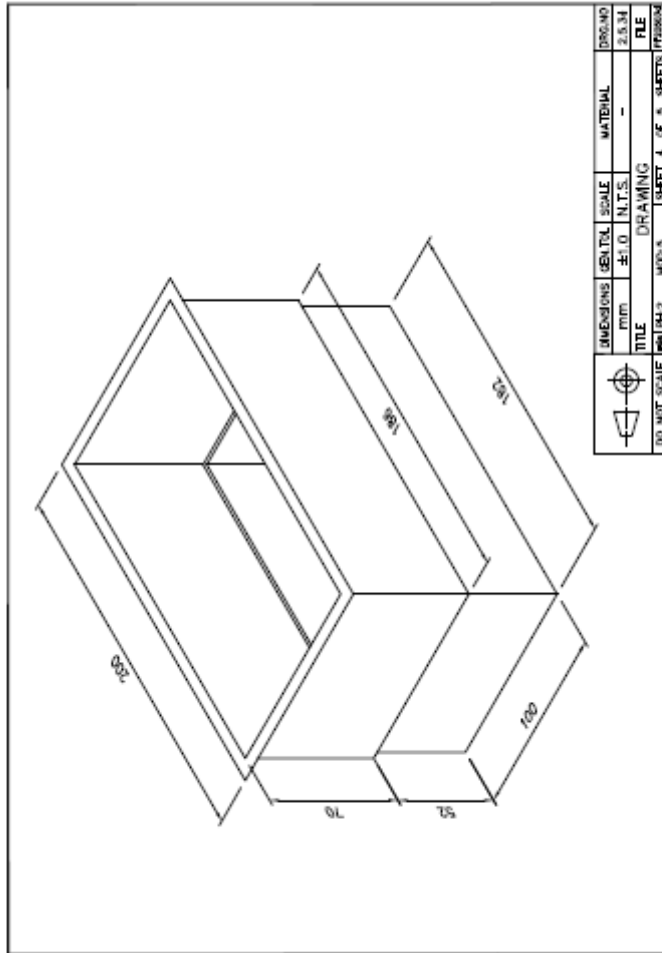

	NO NOT SCALE	PH2	NO NOT SCALE	GENL. SCALE	SCALE	MATERIAL	PROG. NO.
				1:1	N.T.S.	-	2.5.3d
TITLE		DRAWING		FILE		PARTS	
		SHEET 4 OF 5 SHEETS					

Standards All drawings interpreted and drawing correct. Drawings neat and balanced

2.5 Exercise No. 2.5.3e

Code XX

Phase 2

Module 5: Unit 3

Pipefitting

Exercise No. 2.5.3e

Instructions

The figure shows the elevation and end view of a 90° function between two cylinders of unequal diameter. Draw the given views and develop a full template for the branch pipe and project a true shape of the hole in the main pipe.

Given a scale of 1:2

Tools and Materials

- Drawing board and clips
- Drawing paper
- Selection of pencils
- Pencil sharpener and eraser
- Tee square, set square and protractor
- Scale rule
- Compass set and accessories

Standards Balanced layout. Neat and tidy. Free from smudging. Correct line types and thickness. To scale as per instruction

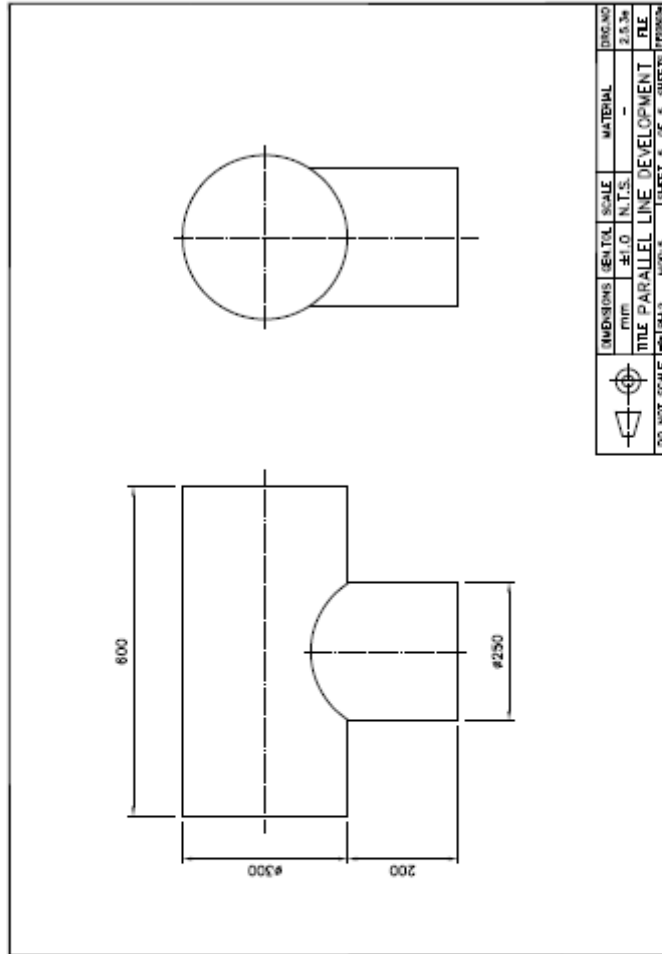

IMENSIONS	UNIT	SCALE	MATERIAL
mm	N.T.S.		
TITLE PARALLEL LINE DEVELOPMENT			
SHEET 5 OF 5 SHEETS			

Exercises

- Identify, select and use the necessary drawing instruments to set up and prepare a drawing sheet for a practical drawing exercise
- Produce basic isometric line drawings and first/third angle orthographic projection drawings for exercise No. 2.5.3a
- Produce basic isometric line drawings and first/third angle orthographic projection drawings for exercise No. 2.5.3b
- Produce basic isometric line drawings and first/third angle orthographic projection drawings for exercise No. 2.5.3c
- Produce basic isometric line drawings and first/third angle orthographic projection drawings for exercise No. 2.5.3d
- Using parallel line development draw the given view of a 90° pipe junction between two pipes of different diameters and develop a full template for the branch pipe, then project a true shape of the hole in the main pipe as per exercise No. 2.5.3e

Additional Resources

Title	Author	Ref. Code
The Induction Book, “ <i>Code of Behaviour & Health & Safety Guidelines</i> ”	SOLAS	
Basic Welding and Fabrication	W Kenyon	ISBN 0-582-00536-L
Fundamentals of Fabrication and Welding Engineering	FJM Smith	ISBN 0-582-09799-1
<i>Workshop processes, practices and materials</i> , 3 rd edition, Elsevier Science & Technology	Black, Bruce J 2004	ISBN-13: 9780750660730
New Engineering Technology	Lawrence Smyth & Liam Hennessy	ISBN 086 1674480

Videos:

- Understanding welding fumes
- Welder on Site...Be Aware (Vocam)
- Powered hand tool safety (Vocam)
- Industrial Ergonomics (Vocam)

Available from:

Vocam Ireland

Circle Organisation Ltd

Friar Street, Thurles, Co Tipperary, Ireland

Tel: +353 504 24666

SOLAS

An tSeirbhís Oideachais Leanúnaigh agus Scileanna
Further Education and Training Authority

*Castleforbes House
Castleforbes Road
Dublin 1*